

MAXCOM 4E

**SOLID STATE 40 CHANNEL
FM 2 WAY RADIO**



Instruction Manual

SPECIFICATIONS

TRANSMITTER SECTION

POWER OUTPUT	4 Watt Max (10dB Hi-Lo Power Switch Provided)
EMISSION	Frequency modulation
SPURIOUS RESPONSE LIMIT	0.25 μ W MAX
MODULATION	FM; Deviation 2KHz MAX

RECEIVER SECTION

CIRCUIT TYPE	Crystal controlled PLL
FREQUENCY	40 channels – 27.60125MHz Thru 27.99125MHz; 10KHz spacing
SENSITIVITY	Less than 1 μ V for 20dB (S+N)/N.
SQUELCH RANGE	0-1mV
SELECTIVITY	60dB down at \pm 10KHz
IF FREQUENCY	1st IF: 10.695MHz 2nd IF: 455KHz
IMAGE REJECTION	60dB typical
AUDIO OUTPUT	3.5W maximum at 8 ohm load
CURRENT DRAIN	250mA on stand by [no signal]
CURRENT DRAIN (MAXIMUM)	Less than 1.5A
ANTENNA	Nominal 50 ohms impedance
POWER SOURCE	Operates from nominal 13.2 volts DC, negative ground system
DIMENSIONS [OVERALL]	5-3/16(W) x 7-1/2(D) x 2-1/8(H) inches
WEIGHT	3 lbs.

DESCRIPTION

This model is an all solid state 2-way radio transceiver for mobile operation. A frequency synthesizer circuit provides 40 crystal controlled PLL transmit and receive channels in the 27MHz Band, engineered for trouble-free performance. Your transceiver uses heat resistant transistors in all critical areas. Current drain on 12 volts DC is exceptionally low. Operation over long periods is feasible even with your engine turned off. The transceiver may also be operated by using an optional AC to DC Regulated 12-Volt Power Supply.

RECEIVER

The receiver is a sensitive and highly selective dual-conversion superheterodyne type providing crystal-controlled PLL operation on all 40 channels. The circuit incorporates a number of features designed to provide optimum reception. The receiver incorporates an effective audio stage. A ceramic filter provides sharp selectivity and high adjacent channel rejection. As a result transmissions on adjacent channels cause minimum interference. A variable squelch control is incorporated to "silence" the receiver when no signals are being received. The squelch circuit is adjustable providing varying degrees of sensitivity to incoming signals.

TRANSMITTER

The transmitter offers stable operation delivering a full 4 watts RF output. High efficiency transistors IC chips and low loss components are used for high reliability.

POWER SUPPLY

The transceiver is ready for connection to a 12 volt DC, negative ground system. DC power is provided to the transceiver by means of a fused power lead.

OPERATING CONTROLS AND FEATURES

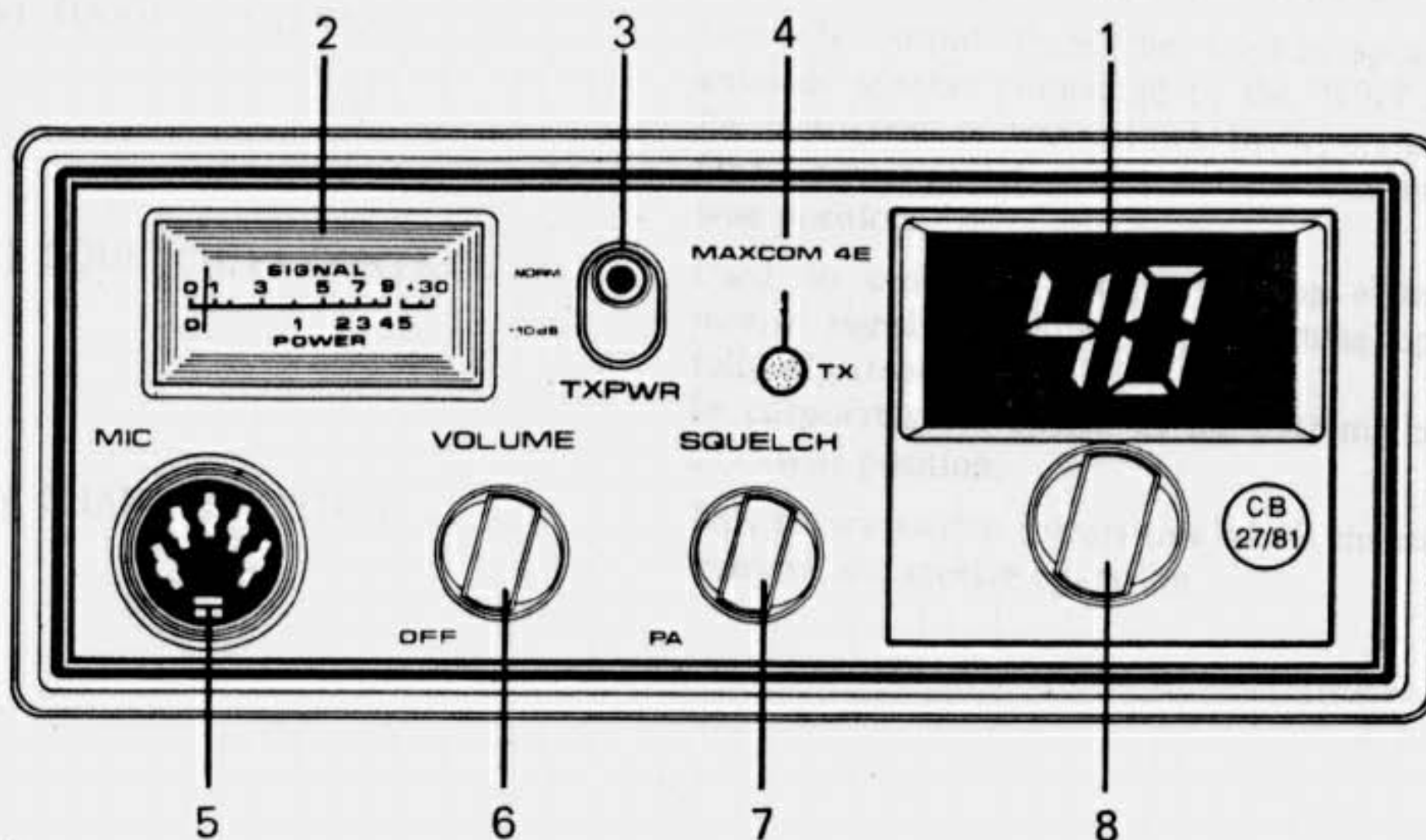

FIGURE 1

- | | |
|------------------------------------|--|
| (1) L.E.D. DISPLAY | L.E.D. (Light Emitting Diode) lamp Indicates the channel selected by 40 position rotary switch. |
| (2) S/P-RF ILLUMINATED METER . . . | Indicates relative incoming signal strength (top scale) and relative RF power output (bottom scale) when transmitting. |
| (3) HI-LOW POWER SWITCH. | Reduced power by 10dB. For use when antenna exceeds height of 7 meters. Refer MPT 1320 regulations. |
| (4) TX INDICATOR LIGHT | Lights up when you are transmitting. |

- (5) MICROPHONE INPUT 5 Pin socket for push-to-talk microphone.
- (6) ON-OFF/VOLUME Controls output from the built-in speaker, or external speaker connected to the "EXT SP" or PA jack (rear of transceiver). Incorporates "ON-OFF" power switch at the extreme counter-clockwise position.
- (7) SQUELCH, PA CONTROL Used to quiet the receiver during absence of receive signals. Sensitivity to incoming signals is fully adjustable.
Incorporates PA switch at the extreme counter clockwise position.
- (8) CHANNEL SWITCH This rotary switch selects one of 40 channels for transmit and receive operation.

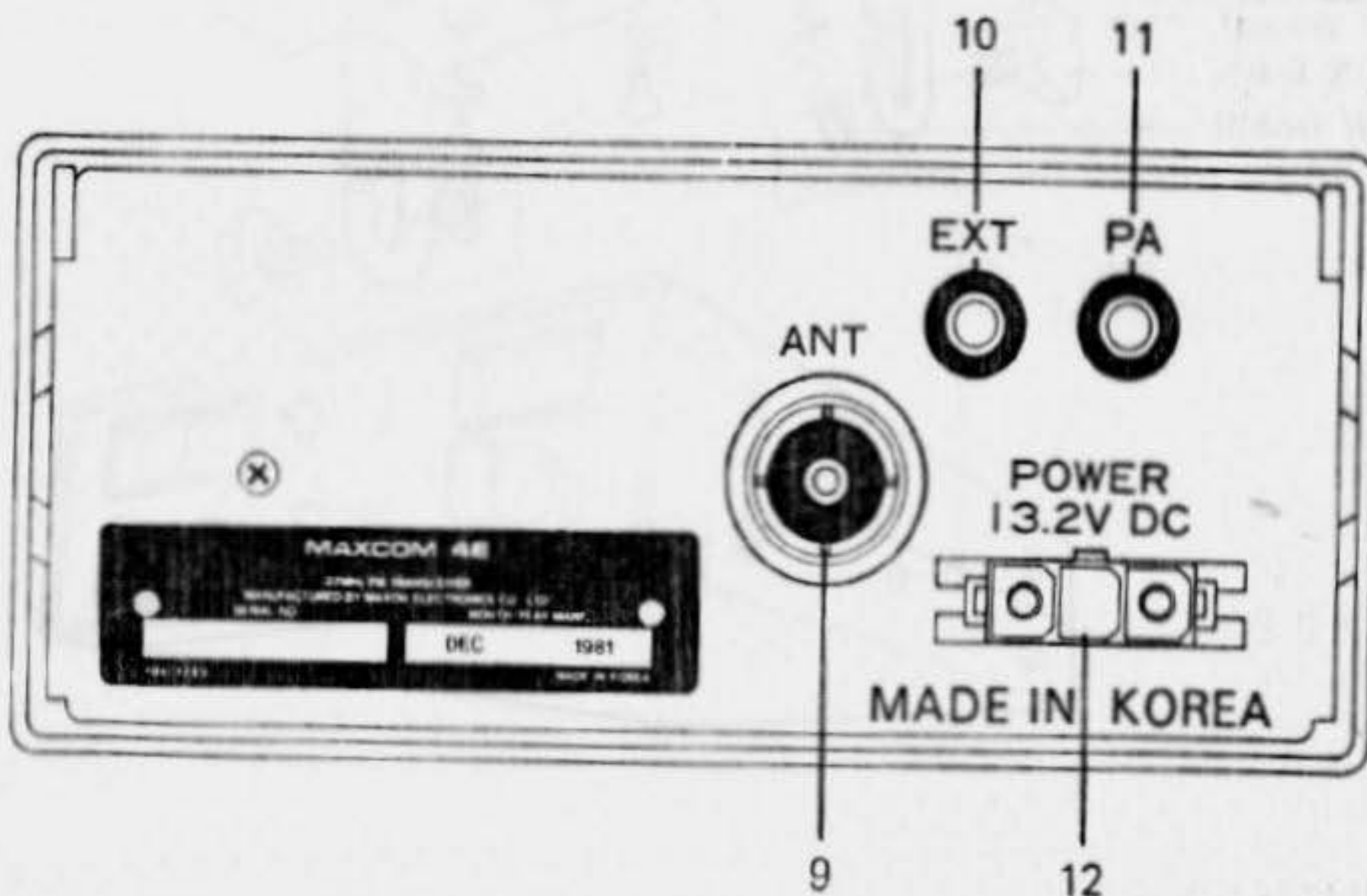

FIGURE 2

- (9) ANTENNA CONNECTION To match antenna lead-in cable [RG-58 RG-8U] with PL-259 type coaxial connector.
- (10) EXTERNAL SPEAKER JACK Impedance of any device such as headphone connected to this jack should be 4-8 ohms. Insertion of plug into jack automatically silences the transceiver internal speaker.
- (11) PA SPEAKER JACK For Public Address [PA] operation. Horn impedance should be in 4-8 ohm range.
- (12) DC POWER SOCKET 12 volts DC for transceiver supplied through DC power Cable to this socket.

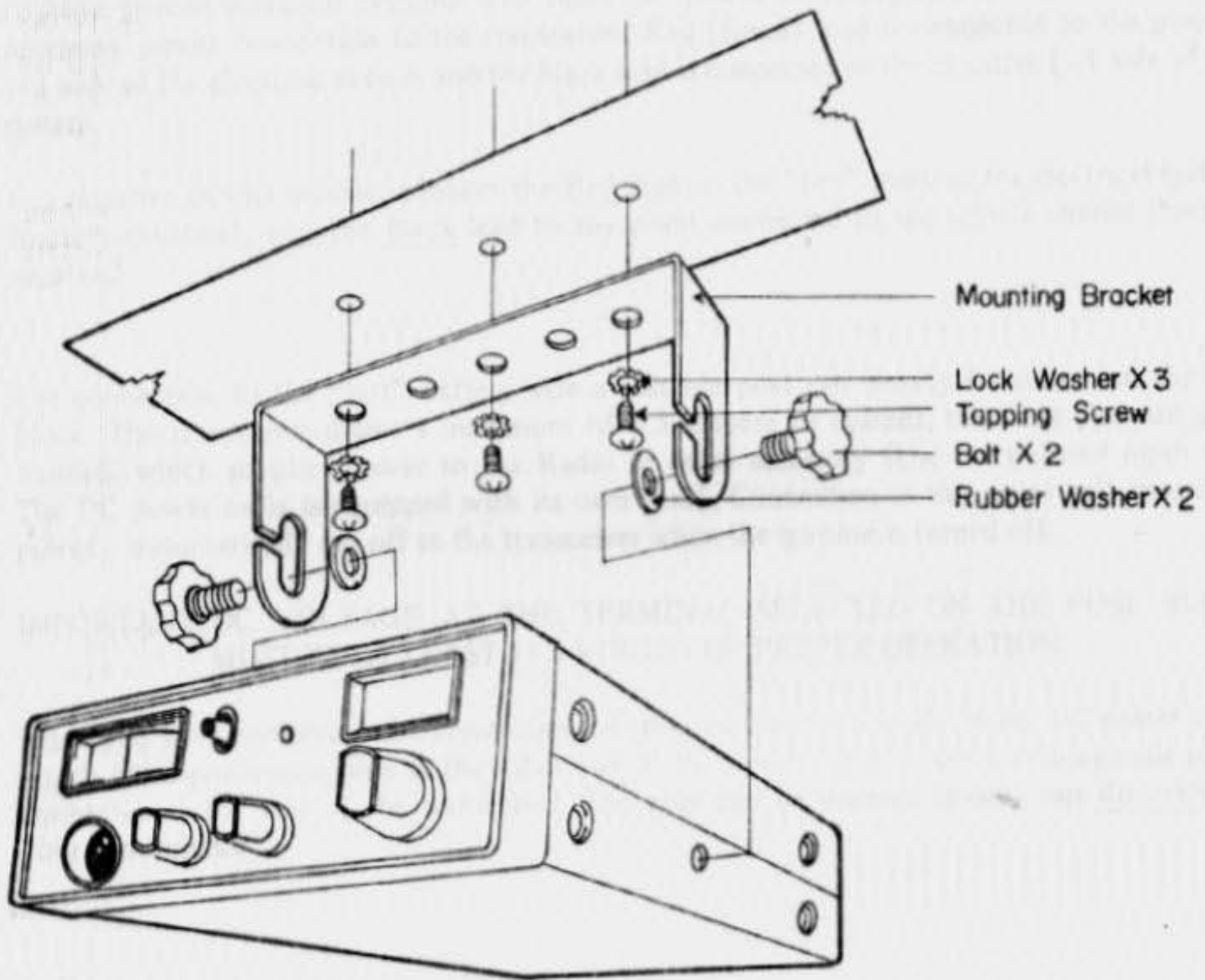

FIGURE 3. MOBILE MOUNTING

TRANSCEIVER INSTALLATION

MOUNTING

Always mount where controls are readily accessible. Unit may be mounted to the underside of the dashboard of a car, truck, etc., utilizing special bracket included with transceiver [see Figure 3]. Attach bracket to the underside of dashboard using the self-tapping screws supplied. Attach the transceiver to the bracket using the two knurled securing screws at the side.

Tilt the unit to the most convenient angle before tightening securing screws.

DC POWER CONNECTIONS

The transceiver is designed to operate from a battery source of 11.5 to 14.5 volts DC, employing negative ground electrical systems. The fused DC power cable supplied is used to make the necessary power connection to the transceiver. Red [fused] lead is connected to the positive [+] side of the electrical system and the black lead is connected to the negative [-] side of the system.

In a negative ground vehicle, connect the Red lead to the "hot" point in the electrical system [battery positive], and the Black lead to any point connected to the vehicle chassis [battery negative].

For connection to the "hot" battery side a suitable post can usually be found on the fuse block. The transceiver draws a maximum of 1.5 ampere of current, therefore you can use a terminal which supplies power to the Radio or other accessory [Use the unfused input side. The DC power cable is equipped with its own fuse]. Connection at this point will ensure DC power is automatically cut off to the transceiver when the ignition is turned off.

**IMPORTANT DC VOLTAGE AT THE TERMINAL SELECTED ON THE FUSE BLOCK
MUST BE AT LEAST 11.5 VOLTS FOR PROPER OPERATION.**

When you have completed the connections of the red and black leads of the DC power cable, attach the 3-pin female plug at the other end of the power cable to the matching male power connector at the rear of the transceiver. The plug can be inserted in only one direction for your convenience.

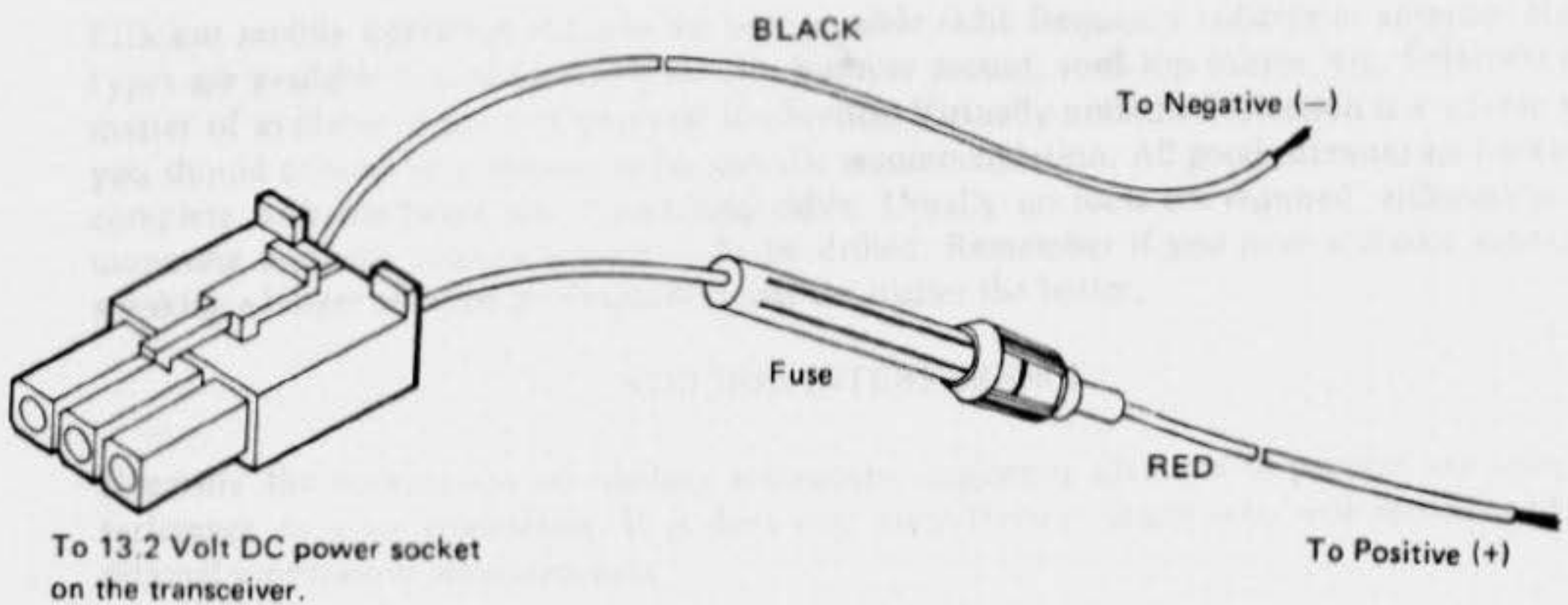

FIGURE 4. CONNECTING DC POWER CORD

ANTENNA CONNECTION

The lead-in cable from the antenna must be terminated with a PL-259 type male connector. Attach to the matching antenna input connector at the rear of the transceiver.

MICROPHONE BRACKET

Attach the microphone bracket provided to any convenient location.

MICROPHONE CONNECTION

Insert the 5-pin plug at the end of the coiled cord into the microphone socket.

DO NOT TRANSMIT WITHOUT AN ANTENNA CONNECTED TO THE TRANSCEIVER.

ANTENNAS

Efficient mobile operation requires the best possible radio frequency radiator or antenna. Many types are available including trunk mount, bumper mount, roof top mirror, etc. Selection is a matter of available space and personal preference. Virtually unlimited selection is available and you should consult your dealer for his specific recommendation. All good antennas are packaged complete with hardware and connecting cable. Usually no tools are required, although some mounting methods require a small hole be drilled. Remember if you have a choice generally speaking a longer antenna performs best and the higher the better.

IGNITION INTERFERENCE

Normally the suppression on modern automotive engines is adequate to prevent annoying interference to your transceiver. If it does not, consult your dealer who will recommend additional suppression measurements.

RECEIVING

1. Select desired channel using the rotary channel selector knob
2. Rotate "squench" control to the extreme counter clock position. (but not in P.A. mode)
3. Rotate the "VOLUME/ON-OFF" switch clockwise, to apply power. Operation will be instantaneous.
4. Set the "VOLUME/ON-OFF" switch clockwise to a comfortable listening level (approximately 1/3 setting). The receiver is now ready to operate.

SQUELCH/PA ADJUSTMENT

The Squelch control eliminates annoying background noise in the absence of signals. To adjust the SQUELCH control properly turn up VOLUME until background noise is heard. Rotate the SQUELCH slowly clockwise until the background noise just disappears. At this point the receiver will be quiet under "no-signal" conditions, however a reasonable strength incoming signal will overcome the squelch action and be heard. As the control is advanced the squelch action is progressively increased and stronger incoming signals are needed to overcome it. To receive weak signals or to disable the squelch circuit turn the control counter clockwise.

EXTERNAL SPEAKER AND P.A. JACKS

Recommended plug for the EXT SPEAKER AND P.A. jacks is a "MINIPLUG" subminiature (3.5mm) phone plug. The impedance of earphones or speakers connected should be 8-16 ohms. Insertion of a plug automatically silences the transceivers internal speaker.

SIGNAL STRENGTH METER

When receiving this meter provides a relative indication of signal strength in "S" units providing a means of comparison between one received signal and another.

TRANSMITTING

To transmit, depress the push-to-talk button on the microphone. The Red Transmit Indicator light will come on and will "flicker" slightly as you speak into the microphone. Use the microphone like a telephone speaking several inches from the face. Do not shout, use a normal speaking voice.

When you are transmitting, the receiver is silenced and reception is, therefore, impossible. In the same way, your signal cannot be heard by another station when he is transmitting each must take turns. To receive again, simply release the microphone push-to-talk button.

INDICATING METER

In transmit position the METER gives a relative indication of antenna RF power output on the bottom power scale. As you speak, the pointer should "flicker" slightly, indicating you are modulating the RF carrier. The RF power meter will read true antenna power output when the transceiver is connected to a 50-OHM resistive load. The level indicator indication will not be accurate if the load is mismatched but this will not adversely affect operation if a standard good quality antenna is used.

USE AS PUBLIC ADDRESS SYSTEM

Provision has been made for Public Address [PA] operation utilizing the microphone and audio stages in the transceiver. For PA operation, use an external high-efficiency public address horn-type speaker with an impedance range of 4 to 8 ohms. Connect to the PA jack on the rear panel of the transceiver. The required plug is a subminiature phone plug,

PA volume is controlled by the receiver volume control. To switch to PA position, the squelch control must be rotated to extreme counter clockwise position until it clicks to a stop.

CRYSTAL CONTROLLED "PHASE LOCKED LOOP" SYNTHESIZING SYSTEM

This transceiver uses a frequency synthesizing system which employs a PLL (phase locked loop) circuit to produce 40 transmitting and 40 receiving channels.

TRANSCEIVER SERVICING

Transceiver has been fully tested prior to shipment and will not normally require further adjustments.

INSTRUCTIONS FOR ALIGNMENT

The following alignment instructions are for use by a qualified technician should your transceiver ever need repair or realignment. After a long period of time and frequent use, it may be necessary to have worn out parts replaced, etc. so the information provided is most useful.

PROTECTIVE COVER

Turn Transceiver over (speaker grille upward), and remove the facing chassis cover (2 screws each side). The speaker is connected by two leads to the main chassis so remove cover with care.

P.L.L CIRCUIT ALIGNMENT

10.24MHz

Connect a frequency counter to the pin 12 and check to see $10.240460\text{MHz} \pm 100\text{Hz}$.

VCO ALIGNMENT

1. Set the Radio to channel 40 and in transmit mode. (make certain 50 ohm dummy load or wattmeter is connected to antenna terminal).
2. Connect a circuit tester between T.P. and ground.
3. Adjust L116 to obtain +2.5V DC
4. Set the Radio to channel 1 and in receive mode.
5. Check to see the T.P. DC voltage dropping to a level 2 Volt DC.

As long as the DC level stays between .2.5V DC for Transmit at channel 40 and 2 to 4V DC for receive at channel, the VCO is set properly.

The magnitude of the T.P. voltage swing is determined by C219 at factory. The optimum value of C219 was found to be around 27 pfd.

ALIGNMENT OF TRANSMITTER CIRCUITRY

RF DRIVER STAGE ALIGNMENT

1. Select channel 20.
2. Connect an oscilloscope to the base of Q111.
3. Adjust L107, L109, L108 for maximum amplitude of scope display (27.79125MHz).
4. Connect the scope to Q112 Base.
5. Adjust L110 for maximum amplitude on scope display.

RF POWER AMPLIFIER ALIGNMENT

1. Set power supply voltage to 13.2V and set the Radio to channel 20 position.
2. Connect a watt meter to the antenna connector.
3. Adjust L111, L112, L113 and 115 for maximum power indication. Also again touch up L110, L108 and L109 to peak power.
4. When all coils are peaked, the power meter should indicate above 4.0 watt.
5. Turn L115 counterclockwise until the power reading of 3.8 watt is obtained.

TRANSMIT FREQUENCY CHECK

1. Set the Radio to transmit mode with no modulation.
 2. Connect the frequency counter to the antenna load or to the tab provided at the wattmeter.
- The frequency should be within $\pm 800\text{Hz}$ from each channel center frequency as tabulated in the frequency table attached.

MODULATION SENSITIVITY ALIGNMENT

1. Set the unit into transmit mode and apply 20mV, 1KHz signal to the Mic input circuit.
2. RV105 2.2KHz deviation at this condition.
3. Next, decrease signal input to 6mV and observe that the deviation ratio is keeping the value higher than 60%.

RF METER ALIGNMENT

Adjust RV103 so that the meter pointer should indicate the same wattage as the reading obtained on the wattmeter. Refer to "3.6" in this alignment procedure.

ALIGNMENT OF RECEIVER CIRCUITRY

RECEIVER SENSITIVITY ALIGNMENT

1. Set the signal generator at 27.79125MHz, 1KHz and 1.5KHz deviation. Also set the radio at channel 20 position.
2. Adjust T5, T6, T7, T8, T9, and L105 for maximum audio output across the 8 ohm dummy load resistor.

SQUELCH CIRCUIT ALIGNMENT

1. Set the signal generator to provide RF input signal of 50dB (1KHz, 1.5KHz deviation.)
2. Rotate the squelch control in full clockwise direction.
3. Temporarily adjust RV101 for maximum audio output, and note the audio output level. Then, adjust RV101 for optimum squelch action.

S-METER ADJUSTMENT

1. Set the signal generator to provide 40dB signal output.

BLOCK DIAGRAM

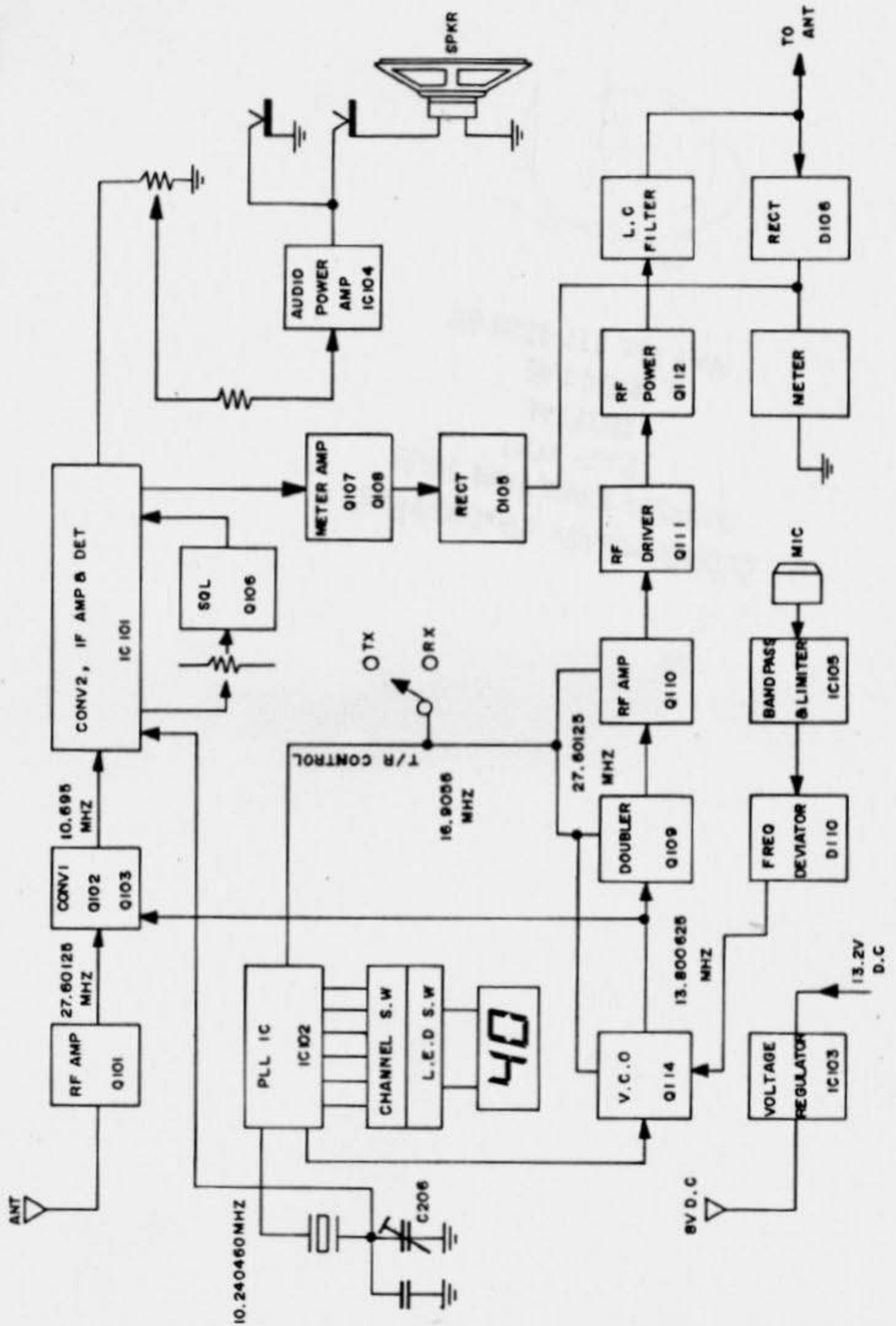

Marksmith Autosales

303/305 CARLTON HILL

CARLTON

NOTTN.

NG4 1JE

VAT No. 117 4228 87